

# NOVA™ STORAGE BUNKER

## OPERATION & MAINTENANCE MANUAL

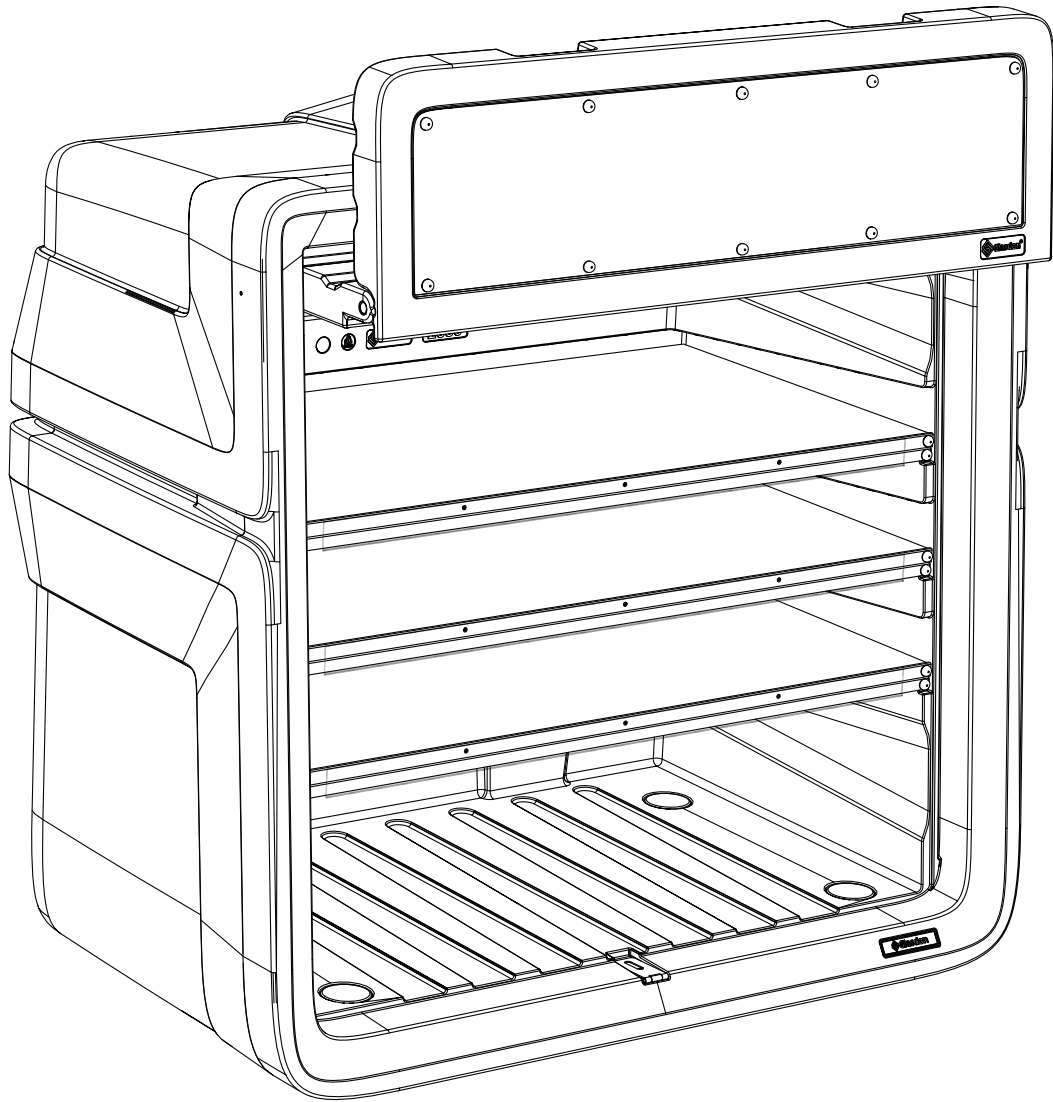

# OPERATION & MAINTENANCE MANUAL

<b>CONTENTS</b>		<b>PAGE</b>
<b>SECTION 1</b>	<b>DOOR OPERATION</b>	
	Opening Door	3
	Closing Door	3
<b>SECTION 2</b>	<b>SHELF KIT</b>	
	Moving Shelving Location	4
<b>SECTION 3</b>	<b>OPTIONAL EXTRA KITS</b>	
	Rain Deflection Cover - Removal	5
	Wheel Kit - Brake	5
<b>SECTION 4</b>	<b>FOAMEX GRAPHICS</b>	
	Replacing the Sign	6
<b>SECTION 5</b>	<b>CLEANING</b>	
	Bunker (Body & Door)	7
	Maintenance	7

# SECTION 1 - DOOR OPERATION

## OPENING DOOR

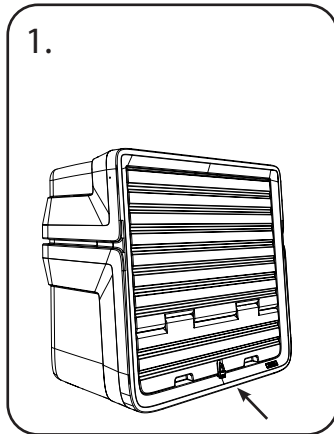

1. Unlock the padlock at the bottom of the door and remove. Release the lock catch from the door.

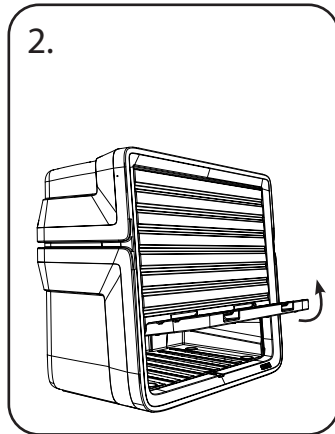

2. Using the two handle recesses, lift the bottom section of the door upwards until the hinge locks in place.

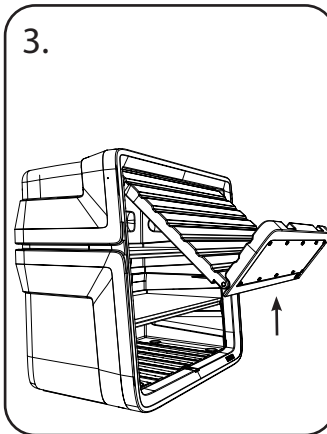

3. Lift the door up until it reaches 90 degrees, and is perpendicular with the unit.

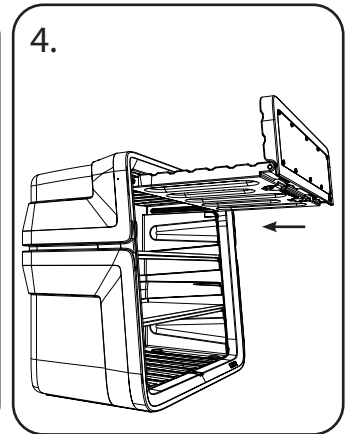

4. Push the door back into the body of the unit until it can go no further.

## CLOSING DOOR

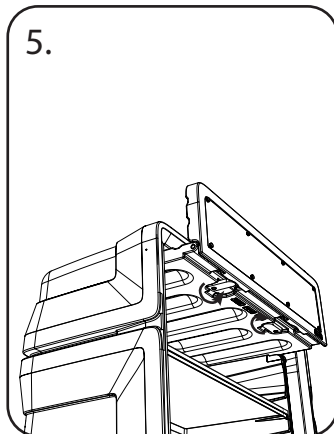

5. Lock the bottom section of the door in the upright position by twisting the swing tabs 90 degrees clockwise on the underside of the door to lock.

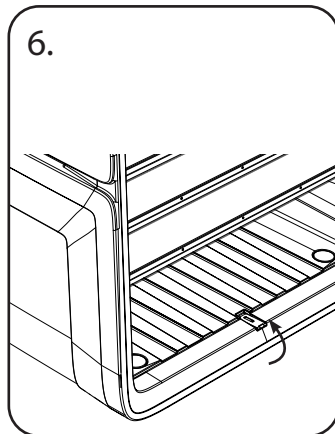

6. Hinge the hasp lock so that it is folded into the recess in the base of the unit.

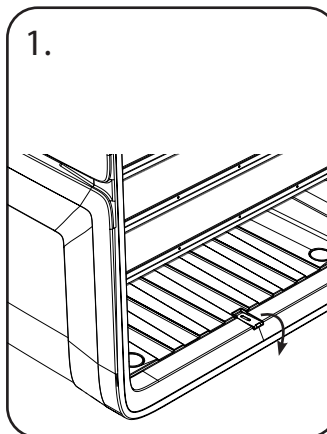

1. Hinge the hasp lock by folding it outwards from the base of the unit.

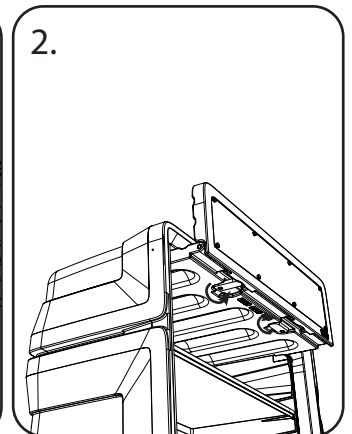

2. Twist the tabs anti-clockwise on the underside of the door to release.

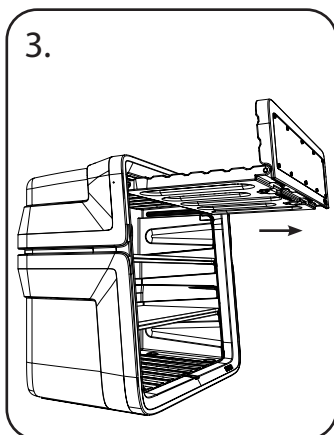

3. Ensuring you have a good grip on the top of the door, begin to slide the door out from the unit.

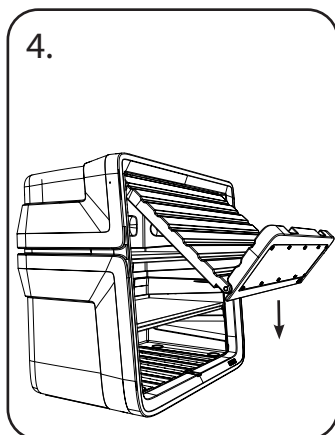

4. Once the door is fully extended, begin to lower the door down.

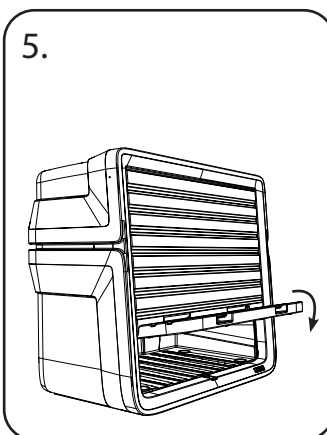

5. Push down on the bottom section on the door to release the locked hinge and allow the door to sit flush with the unit.

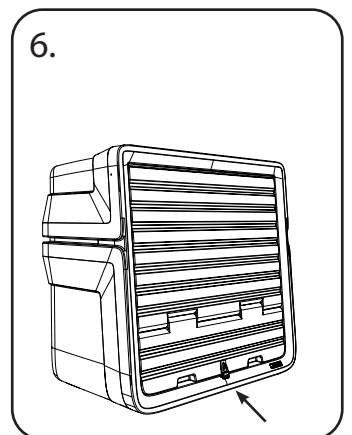

6. Lift the lock catch upwards to locate the bracket on the door. Feed the padlock through the hole in the bracket and lock.

## SECTION 2 - SHELF KIT

### MOVING SHELVING LOCATION

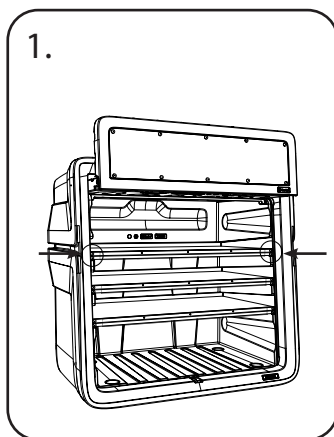

1. To remove a standard shelf locate the cover caps at each end of the shelf.

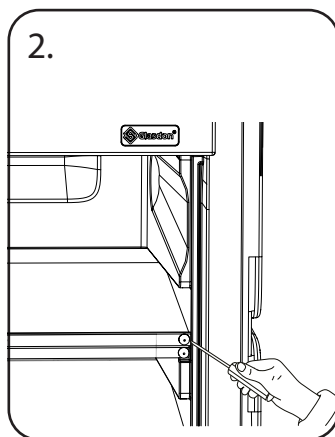

2. Using a flat headed screwdriver gently pry off the cover cap to reveal the fixing underneath.

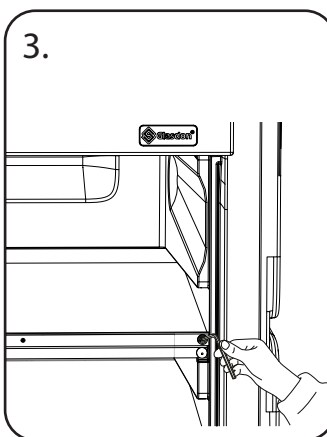

3. Using a 4mm Allen key remove each fixing and cap ring.

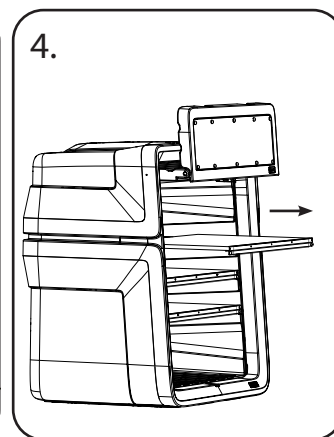

4. Grip at the edges of the shelf and carefully pull the shelf forwards to slide it out of the unit.

## SECTION 3 - OPTIONAL EXTRA KITS

### RAIN DEFLECTION COVER - REMOVAL

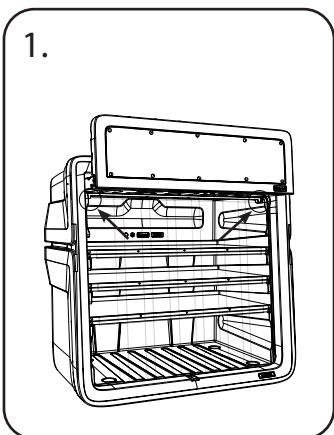

1. Locate the fixings on each end of the metal support bar that attach to the inside of the body.

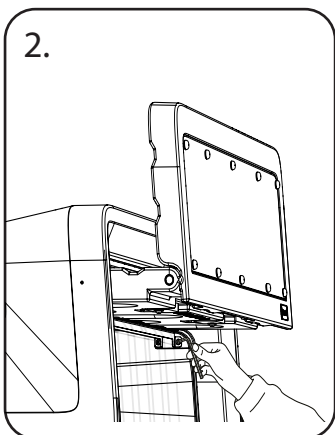

2. Using a 4mm Allen key gradually loosen the fixings at each end of the support bar to detach it. Support the rail whilst removing the fixings.

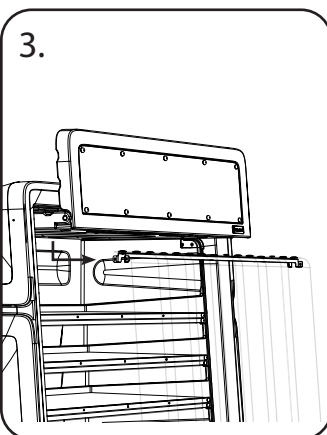

3. Once the rail is detached lower and remove the rain cover from the unit.

### WHEEL KIT - BRAKE

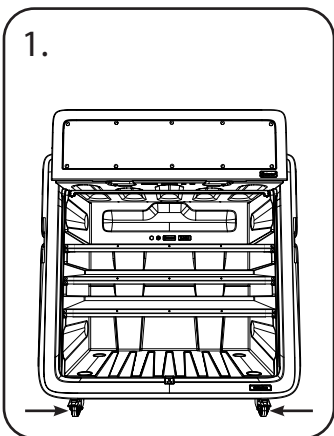

1. The storage bunker can be wheeled with use of the caster wheel kit.

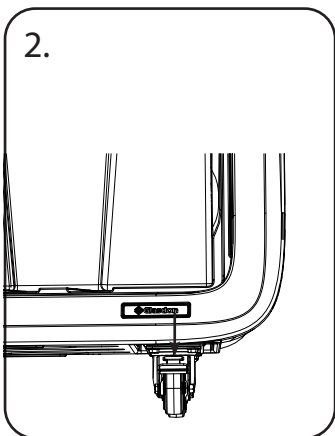

2. Push down on the lever to engage the brake located on each of the two front wheels.

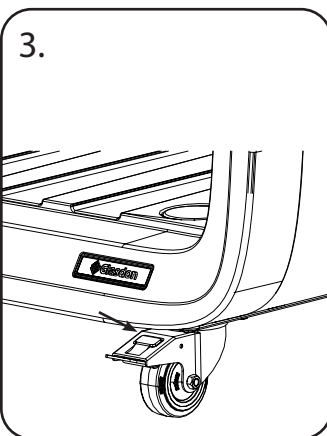

3. To release the brake push down on the smaller lever.

## SECTION 4 - FOAMEX DISPLAY SIGN

### REPLACING THE SIGN

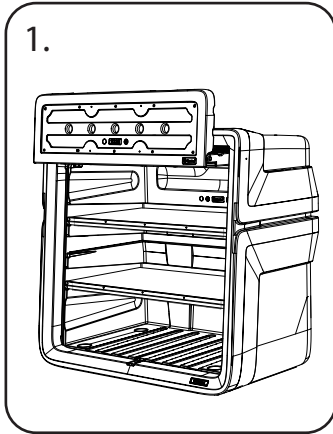

Open the unit and lock the door into place using the two swing tabs as shown in Section 1.

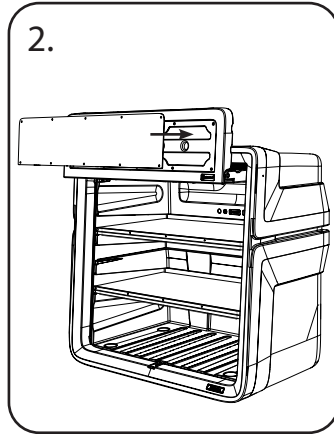

Position the Foamex board into the recess on the inside of the door.

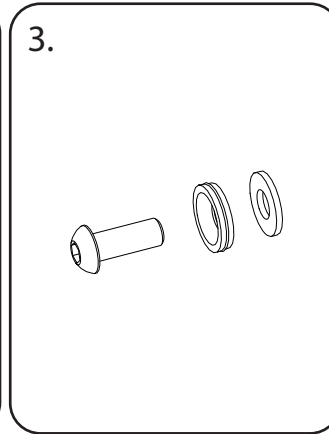

Slide the cap rings and washers onto to the M6 screws as shown above. Insert the 10 screws into the holes.

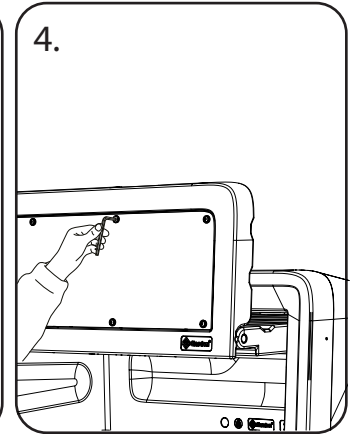

Using a 4mm Allen key, tighten each bolt.

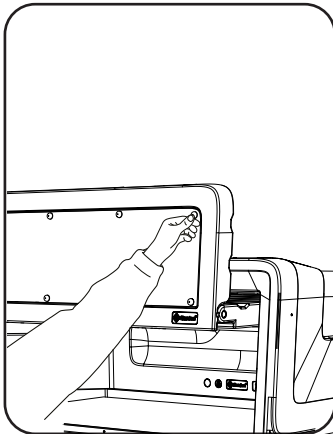

Push a cover cap over each bolt to hide the fixing.

## SECTION 5 - CLEANING

### CLEANING YOUR STORAGE UNIT

We would recommend a warm pressure wash with soap or alternatively hand wash with 10% solution of mild detergent in warm water using a soft bristle brush followed by a rinse with clean water.

Felt tip marker pens or paint may be removed from the Durapol using a proprietary graffiti remover. Carefully follow the instructions, particularly the guidelines covering safety. Ensure that all traces of chemicals are removed once the graffiti has been erased, then clean as detailed above.

#### **Caution**

Many graffiti removers can damage banding and stickers. Use only on the areas of the Durapol affected and do not use on areas of banding or graphics.

### MAINTENANCE

A planned maintenance schedule of regular inspection is recommended and components replaced when necessary.





 **Glasdon** , DURAPOL & NOVA ARE TRADEMARKS OR REGISTERED TRADEMARKS OF GLASDON GROUP OR ITS SUBSIDIARIES IN THE U.K. AND OTHER COUNTRIES.

- A planned maintenance schedule or regular inspection is recommended, replacing components as necessary.
- Replacement components are available direct from GLASDON.
- GLASDON cannot be held responsible for claims arising from incorrect installation, unauthorised modifications or misuse of the product.

Stock No. C000/1047 - DWG No. 16B096-31 Issue 1 - January 2024

© Copyright 01/2024

Glasdon UK Ltd reserve the right to alter specifications without prior notice.

 **Glasdon**<sup>®</sup>  
**Glasdon U.K. Limited**  
Preston New Road  
BLACKPOOL  
Lancashire  
FY4 4UL  
Tel: (01253) 600410  
Fax: (01253) 792558  
e-mail: sales@glasdon-uk.co.uk  
web: www.glasdon.com